



Product & Support Information

**'406' FRONT WHEEL DRIVE
TOURING CAR/RALLY CAR
GEARBOX**



**Xtrac Limited
Gables Way
Kennet Park
Thatcham
Berkshire
RG19 4ZA
England**

**Tel: +44 1635 293800
Fax: +44 1635 293700**

www.xtrac.com



Who are Xtrac?

Xtrac was started in 1984, with the aim of offering the motor racing industry a complete bespoke transmission service including design, manufacture and assembly. From the outset the product has been targeted at the world's top racing formulae including F1, IRL, CART, World Sports Cars, Touring Cars and World Rally Cars. Today, the company supplies well over 70% of the transmission parts for all these forms of racing.

Xtrac employs over 200 people and works 24 hours a day on at least 6 days of the week (and often 7!). Our 88,000 sq. ft facility houses the very latest high technology machinery, supported by a design and engineering staff of over 50 people, with extensive quality control measures to ensure the highest component and product quality. All transmissions are assembled to the highest standards by our build shop, who also utilise R & D dyno facilities to carry out pre-delivery testing of every new and overhauled assembly.

Xtrac '406' FWD Touring Car/Rally Car Gearbox

Xtrac's transverse front wheel drive gearbox has been designed to suit both Touring Car and Super 1600 Rally Car applications.

Value engineered to meet strict cost constraints, this gearbox offers high quality at a cost effective price.

Standard Specification

- 6 Speed sequential gear selection.
- Weight – Dependent on specification, standard assembly = 37Kg.
- *Design specification (see note * page 6):
 - Power - 280bhp
 - Max RPM - 8500
 - Torque – 260NM
- Standard gearbox casing material is Aluminium L169 (see options below).
- All casting joint faces have 'O'-Ring seals.
- **1st Layshaft gear is integral, 2nd to 6th gears are slide on type. (see note ** page 3)
- Gear teeth are 12.5 mm wide, straight cut on 90 mm centres.
- A list of 26 ratios are available as standard (see options below).
- Reverse gear is sliding Mainshaft type operated from the Barrel.



- Standard final drive ratio = 13:49 (see options below).
- Differential is an Xtrac cassette type plate unit with a choice of ramp angles, plate and preload settings.
- Differential preload adjustment can be performed in the car without disassembly of the cassette.
- Clutch shaft to suit customer installation is included.
- Clutch release slave cylinder (AP Racing CP3859-1250) is included.
- Left hand output flange is integral with the differential, to suit GI 82 size tripod joint.
- Wet sump standard lubrication system (see options below).
- Most components are manufactured in Xtrac's own grade of steel (X36C). Bevel sets, final drives and pinions are manufactured in Xtrac's vacuum melted steel (XVAR1). Highly stressed components are shot peened.

Options

- Super polished gear ratios (Xtrem Process).
- Single stage oil pump/filter lubrication system.
- Right hand side output flange to suit GI 82 size tripod joint.
- Gearchange potentiometer and mounting.
- Quick release detent cable.
- Magnesium casings.
- Resin mock-up gearbox (suitable for show cars, car build etc).

Bespoke Options

- 406 driveshaft assemblies.
- 406 cross shaft assembly.
- Alternative final drive ratio's.

Note**

Rally gearbox – 1st & 2nd gear integral on layshaft.



Prices

Gearboxes

The normal cost for fully assembled and rig tested gearboxes being ordered together and being produced in one batch, is as follows:

£TBA each

Optional Extra's

- Potentiometer kit (includes potentiometer, mounting plate, drive blade, o-ring & circlip).
- Oil pump and filter kit.
- Quick release detent cable.
- LH driveshaft kit (includes shaft, circlip, cap, GKN modified tripod & boot).
- RH driveshaft kit (includes shaft, circlip, cap, GKN modified tripod & boot).
- Cross shaft assembly (includes shaft, circlips, tripod housing with dowels, bolts & adapter flange).
- Outboard CV joint assembly (includes CV joint, Boot & circlip)

Gearbox Mock-up

Although full CAD models can be supplied to assist with installation, if required we can also supply resin mock-up(s). The mock-up's are machined direct from CAD data and offer an accurate external shape of the gearbox assembly for use during car build or for show car/mock up purposes.



Customer Support

Gearbox & Parts Supply

Standard gearbox assemblies and spare parts are generally held in stock at our UK facility. All gearbox assemblies are thoroughly rig tested and inspected prior to despatch to check the gearchange operation, lubrication system and build integrity.

Training/Serviceing

This gearbox has been designed/manufactured for use in cost control categories and thus great emphasis is placed not only on its reliability but also on ease of servicing and assembly.

A technician from each team will be invited to attend product training seminars in the UK, which will provide them with the basic knowledge to carry out their own routine maintenance work. However, if required Xtrac will be able to carry out maintenance/rebuild at facilities in the UK, and subject to demand, at our service centre in the USA.

Customers would receive parts lists and manuals, and when appropriate technical bulletins containing updates on maintenance procedures, parts information, performance and safety issues.

Xtrac's standard terms and conditions of business shall apply to all sales. We may require deposits to be paid with each gearbox order and strict credit limits will have to be in force for each customer.

Further Information

Please contact:

UK

David John Smith, tel: +44 1635 293885, email: dj_smith@xtrac.com

Cliff Hawkins, tel: +44 1635 293841, email: cliff_hawkins@xtrac.com

USA

Andrew Heard, tel: +1 317 472 2454, email: andrew_heard@xtrac.com

Note*

* The rating figure given is considered an approximate, and is dependent on engine characteristic as well as absolute value. The method upon which engine torque is delivered through the transmission can vary considerable depending on the physical engine characteristic, firing order, fuel and spark strategy and any traction limiting system which is utilised. The life and durability of the gearbox internal parts is also considerably influenced by factors other than engine input characteristics, for example oil type, operating temperature and operating environment.

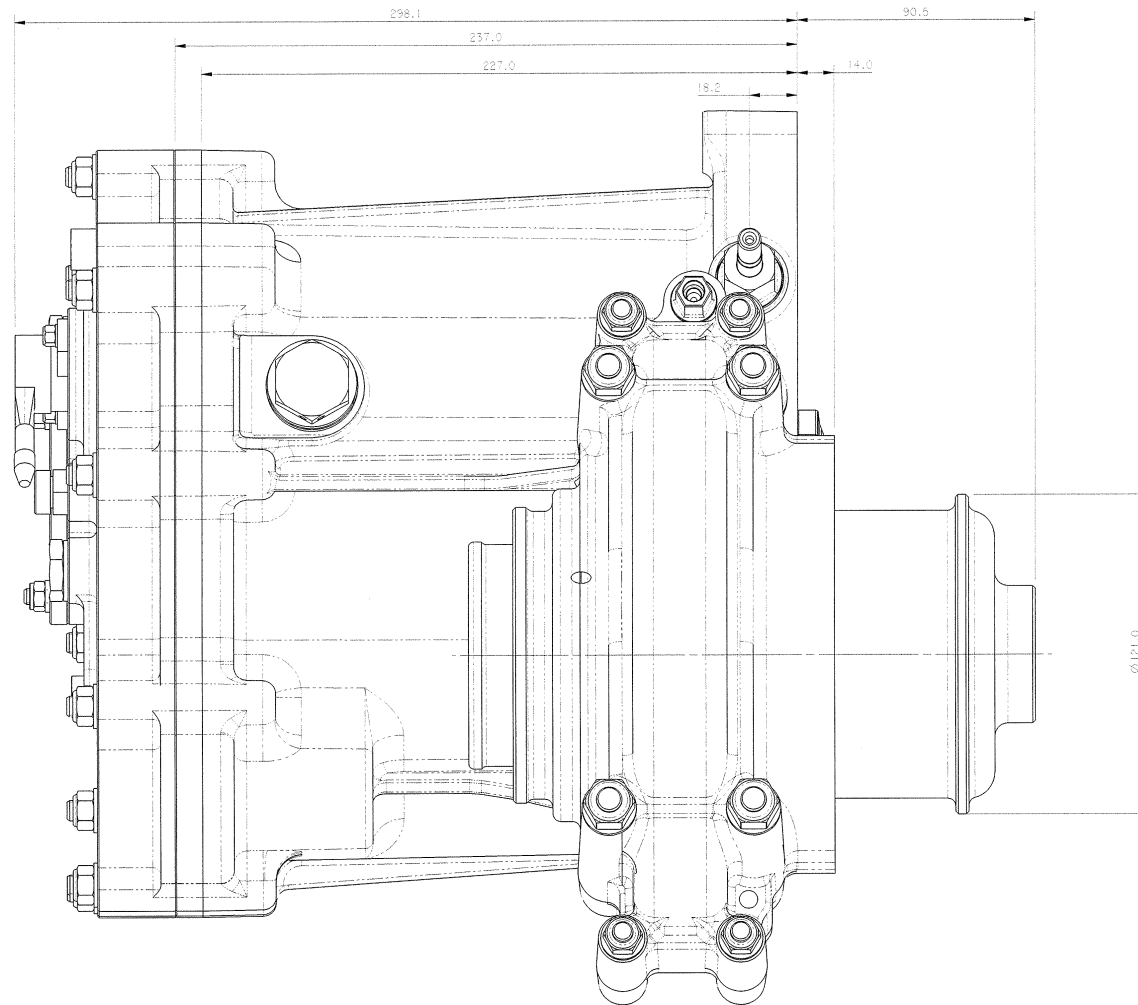

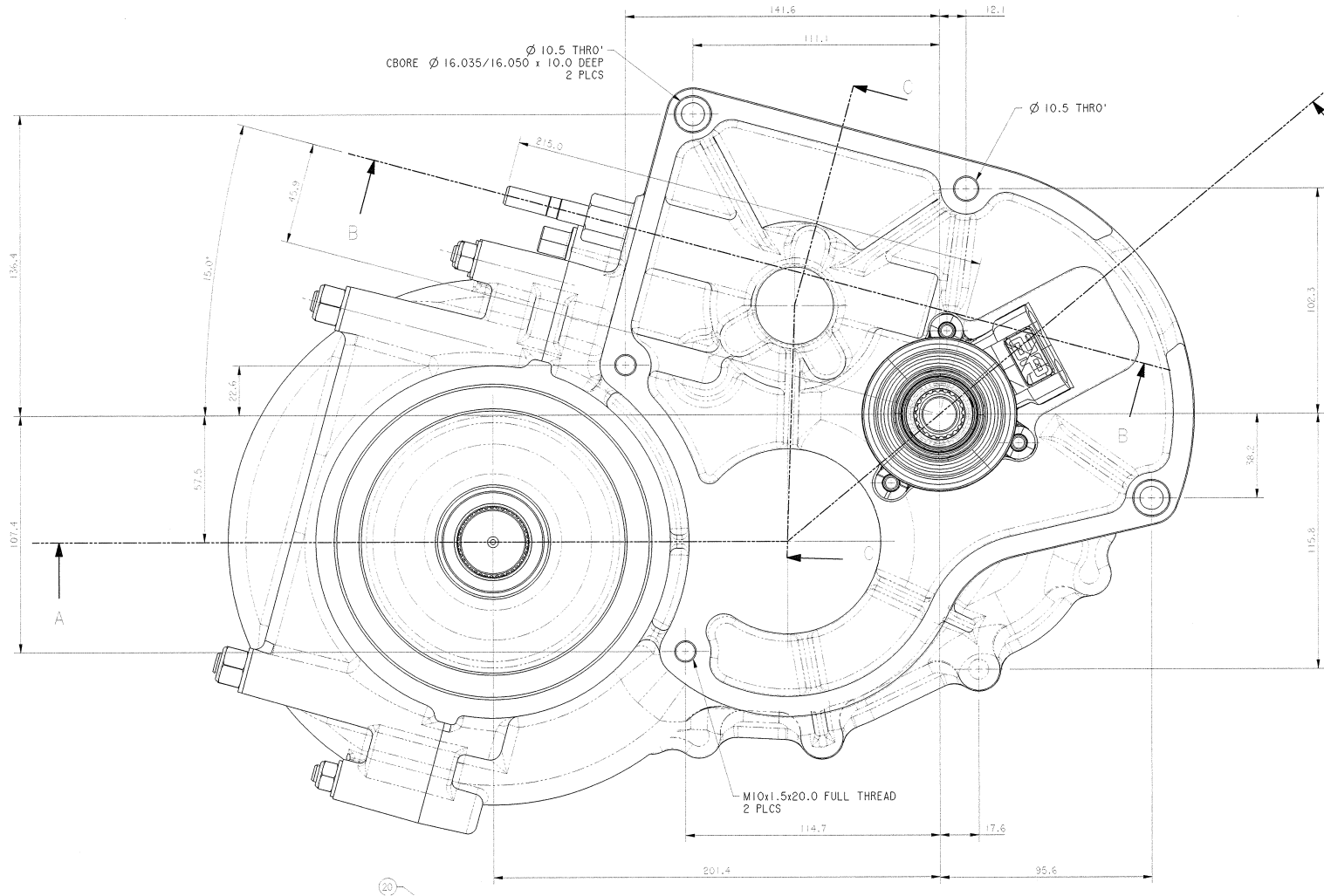

'406' Gearbox Product & Support Information, subject to change without notice – January 2003

TERMS & CONDITIONS OF SALE



1. GENERAL

These terms shall be incorporated into all contracts for the sale of goods by Xtrac to the Customer to the exclusion of any terms stipulated by the Customer. No modification or waiver of these terms shall be binding on Xtrac unless confirmed in writing by Xtrac.

2. DELIVERY

Delivery dates quoted are estimates only and are not binding. Xtrac shall have no liability to the Customer or any third party for any financial or other loss or damage (whether direct or indirect) if delivery is delayed, nor shall any such delay entitle the Customer to refuse to accept any goods or to refuse to pay in full for goods when they are delivered.

Prices quoted are ex-works and exclude freight, insurance and delivery charges, Value Added Tax and other taxes or duties, all of which will be invoiced to the Customer as applicable.

Goods are delivered and risk passes to the Customer when Xtrac makes them available to the Customer or any agent of the Customer or any carrier (who shall be the Customer's agent whoever pays his charges) at Xtrac's premises or other delivery point agreed by Xtrac.

Xtrac does not accept any responsibility for damage, shortage or loss in transit, Xtrac will take reasonable steps to assist the Customer's claim against the carrier for any damage, shortage or loss in transit.

3. QUANTITIES

Orders are accepted on the condition that Xtrac may at its option supply 10% more or less than the quantity ordered.

4. ALTERATION OF PRICES

Xtrac reserves the right to increase the price of the goods to reflect any increase in costs to Xtrac which is due to any factor beyond Xtrac's reasonable control such as (without limitation) any foreign exchange fluctuations; currency regulations; alteration of taxes or duties; increases in the cost of labour, material or other costs of manufacture or delivery; any change in delivery dates, quantities or specifications for the goods which is requested by the Customer; or any delay caused by any instructions of the Customer or failure of the Customer to give Xtrac adequate information or instructions.

5. PAYMENT

Goods will be invoiced when ready for despatch and all invoices are payable in pounds sterling (unless other arrangements have been made). In no circumstances is the Customer entitled to make any deduction or withhold payment.

Where Xtrac has agreed to grant credit to the Customer, payment must be made no later than the thirtieth day of the month following that in which the goods are invoiced. Credit terms may be withdrawn or altered by Xtrac at any time with or without notice.

Without prejudice to any other rights or remedies of Xtrac, if the Customer fails to settle any invoice by the due date interest shall be payable on any overdue amount from the date on which payment was due to that on which it is made (whether before or after judgement) on a daily basis at the rate of 3% per annum above the base lending rate for the time being of Barclays Bank plc. The Customer shall in addition reimburse Xtrac all costs and expenses (including legal costs) incurred in the collection of any overdue amount.

If by reason of failure to pay, late payment or otherwise Xtrac considers that the Customer's creditworthiness is impaired, then without prejudice to any other available remedy Xtrac shall be entitled to suspend further deliveries of goods or to suspend performance of its obligations under any contract with the Customer or treat such contract as repudiated.

6. SUB-CONTRACTING OF WORK

Xtrac reserves the right to sub-contract the whole or part of any work at its absolute discretion.

7. TOOLING

All tooling, fixtures and cutters are invoiced at part cost only and are to remain the property of Xtrac.

8. INFRINGEMENT OF THIRD PARTY RIGHTS

The Customer shall indemnify Xtrac against all damages, penalties, cost and expenses to which Xtrac may become liable as a result of work done in accordance with the Customer's specification or requirements which results in infringement or alleged infringement of a patent, registered design or other intellectual property rights of any third party.

9. CONFIDENTIALITY

All information, technical or otherwise, given by Xtrac to the Customer shall be treated as confidential by the Customer and shall not be disclosed to any third party except with the written permission of Xtrac.

10. OWNERSHIP OF GOODS

Notwithstanding the earlier passing of risk, title in the goods shall remain with Xtrac and shall not pass to the Customer until the Customer has paid for them in full. Until title passes the Customer shall hold the goods as the fiduciary agent and bailee of Xtrac and the Customer shall store or make the goods so that at all times they are identifiable as the property of Xtrac. Xtrac shall be entitled at any time before title passes to require the Customer to deliver up the goods to Xtrac and to enter upon any premises of the customer or any third party to repossess the goods. If the Customer re-sells the goods the entire proceeds of such resale or any claim for such proceeds shall be held on trust for Xtrac without prejudice to any other claim which Xtrac may have against the Customer in respect of the goods.

11. WARRANTY AND EXTENT OF LIABILITY

Xtrac shall have no liability to the Customer (other than liability for death or personal injury resulting from Xtrac's negligence) for any loss or damage of any nature arising from any breach of any expressed or implied warranty, term or condition of the contract or from any negligence or breach of statutory or other duty on the part of Xtrac in connection with the performance or purported performance of or failure to perform the contract other than as set out in this Condition. In no circumstances shall Xtrac be liable for any claims for indirect or consequential injury or damage (including loss of profits) arising from any such matters.

Subject to the provision of Condition 2 which apply in the case of loss or damage in transit, if the Customer establishes that any goods have not been delivered or have been delivered damaged, or are not of the correct quantity, or do not comply with their description, Xtrac shall at its option either (i) replace with similar goods any goods which are so missing or damaged or do not comply with their description or (ii) allow a credit to the Customer for their invoice value or (iii) repair any damaged goods.

In the case of goods not manufactured by Xtrac, Xtrac's sole liability shall be to pass on to the Customer the benefit of any guarantees, conditions or warranties received by Xtrac in respect of such goods.

Subject to the preceding paragraph, if the Customer establishes that any goods are defective and notifies Xtrac to this effect and returns the goods in question carriage paid to Xtrac within a period of six months from the date of delivery Xtrac shall at its option (i) replace with similar goods or repair any defective goods or (ii) allow the Customer credit for their invoice value.

No claim shall arise against Xtrac for any defect arising from any design or specification provided by the Customer or if any adjustments, alterations or other work has been done to the goods by any person other than Xtrac.

In no circumstances shall the liability of Xtrac to the Customer exceed the invoice value of the goods.

12. RETURN OF GOODS

Goods made to special order cannot be accepted back for credit unless incorrect or defective. In other cases where it may be agreed to accept the return of goods for credit, a handling charge may be made at Xtrac's discretion. Such goods must be in resaleable condition and returned carriage paid. No credit will be allowed for goods supplied more than six months previously.

13. LAW

The applicable law shall be the law of England.